

Installation instruction mechanical bypass option

CONTENTS

General	2
1 Installation	
1.1 Environment	2
1.2 Installation instructions.....	2
1.2.1 Installation of BP-2000.....	2
1.2.2 Installation of BP-3000.....	4
1.2.3 Installation of BP-6000.....	5
1.3 Starting UPS.....	6
1.4 Using the Mechanical Bypass.....	6
2. Technical specifications with Bypass Cabinet	7
2.1 Power range 700-3000 VA.....	7
2.2 Power range 5000-6000VA.....	8

General

This manual completes the main User's and Installation manual when the UPS is provided with the Mechanical Bypass option.
Please read first the main manual and install the UPS according this instruction.

1. Installation

1.1 Environment

All the requirements concerning environment described in this chapter (Installation) or chapter 2 (Technical specifications) must be met. If they are neglected the manufacturer cannot guarantee the safety of personnel during installation or use, or that the unit will function properly.

When locating the UPS system and the battery options, the following points have to be remembered:

- Avoid temperature and humidity extremes. To maximise the life time of the batteries, an ambient temperature of 15°C to 25°C is recommended.
- Provide shelter from the elements (especially moisture)
- Make sure that ventilation and space requirements are met for installation of UPS.

1.2 Installation instructions

Mechanical bypass cabinet shall be installed on the wall near the UPS or beside the UPS.



WARNING!

The UPS contains high voltage and current which can injure or kill personnel and damage equipment.

1.2.1 Installing BP-2000

BP-2000 is delivered with 2 IEC-IEC 10 A cables for connecting the UPS to the Bypass cabinet.

The installation procedure for BP-2000 is as follows, see fig 1

1. Decide where you want to have the Bypass, if you want to have it on the wall you have to attach the bypass cabinet with angle pieces to the wall.
2. Connect the Bypass cabinet and UPS with the two IEC-IEC cables supplied with the Bypass cabinet
3. Connect the loads to the Bypass cabinet by using the load cables supplied with the UPS
4. Finally connect the Bypass cabinet to the utility by using the power cable supplied together with the UPS
5. Check that all connections are done accordingly and then you may start the UPS according to description in the UPS user manual

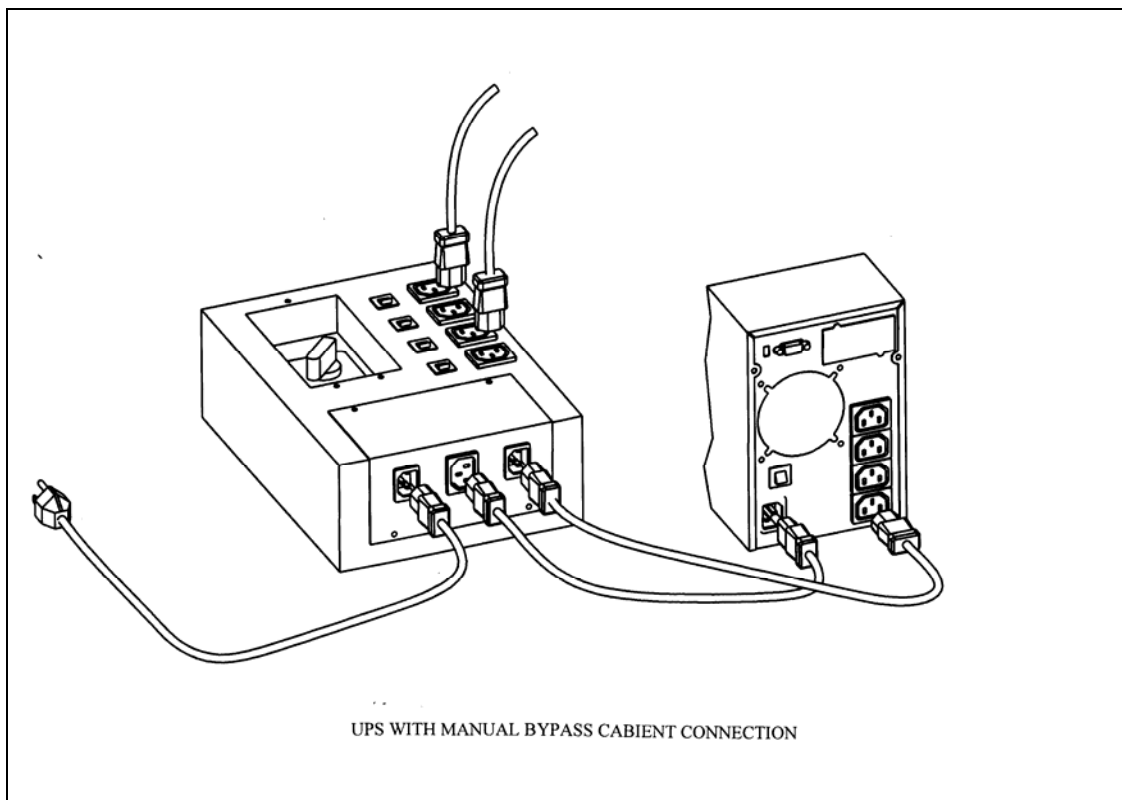

1.2.2 Installing the PW 9120-BP-3000

The procedure is exactly the same as for PW BP-2000 but the cables configurations are different. BP-3000 is delivered with two IEC-IEC 16 A cables and two IEC-IEC 10 A cables

1. Decide where you want to have the Bypass, if you want to have it on the wall you have to attach the bypass cabinet with angle pieces to the wall. If you put the Bypass cabinet beside the UPS please make sure that you leave 50 mm space for the airholes on the right side of the UPS.
2. Connect the Bypass cabinet and UPS with the two IEC-IEC16 A cables supplied with the Bypass cabinet
3. Connect the loads to the Bypass cabinet by using the load cables IEC-IEC 10 A supplied with the Bypass cabinet. You may also use the loadcable supplied with the UPS, when connecting the cable to the 16 A outlet on the bypass cabinet.
4. Finally connect the Bypass cabinet to the utility by using the power cable supplied together with the UPS
5. Check that all connections are done accordingly and then you may start the UPS according to description in the UPS user manual chapter 7.1

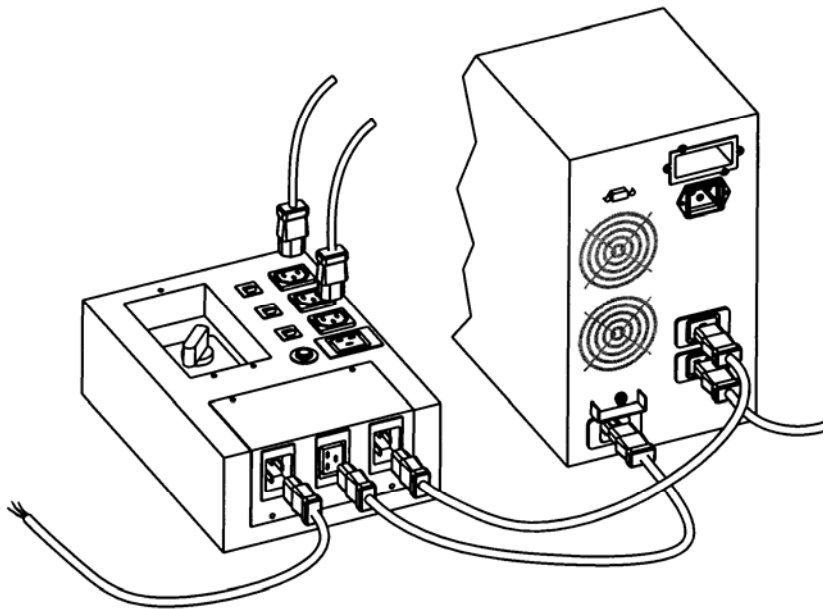

1.2.3 Installing PW 9120-BP-6000

1. Check that electrical connections to the installation site have been properly executed. Also check that fuse ratings and cable dimensions are met according to table below
2. Since the UPS does not have automatic backfeed isolation a warning label must be added on all primary power isolators installed remote from the UPS area to warn electrical maintenance personnel that the circuit feeds a UPS

The warning label shall carry the following wording or equivalent:

ISOLATE UNINTERRUPTIBLE POWER SYSTEM (UPS) BEFORE WORKING ON THIS CIRCUIT

3. Switch off the supply to the distribution point to which the UPS unit is to be connected. Make sure that there is no power
4. Connect the loads to the Bypass cabinet . Finally connect the Bypass cabinet to the utility.
5. Check that all connections are done accordingly and then you may start the UPS according to description in the UPS user manual

	5 kVA	6 kVA
Cable	6 mm ²	6 mm ²
Fuse	25 A	32 A

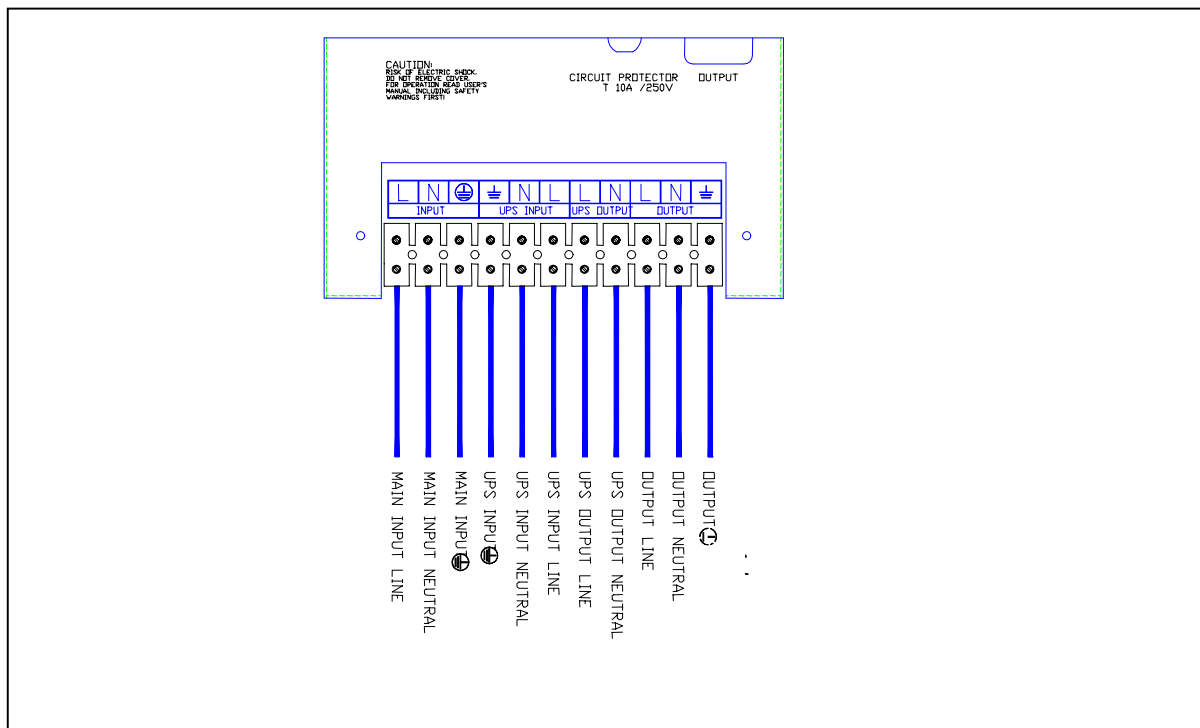

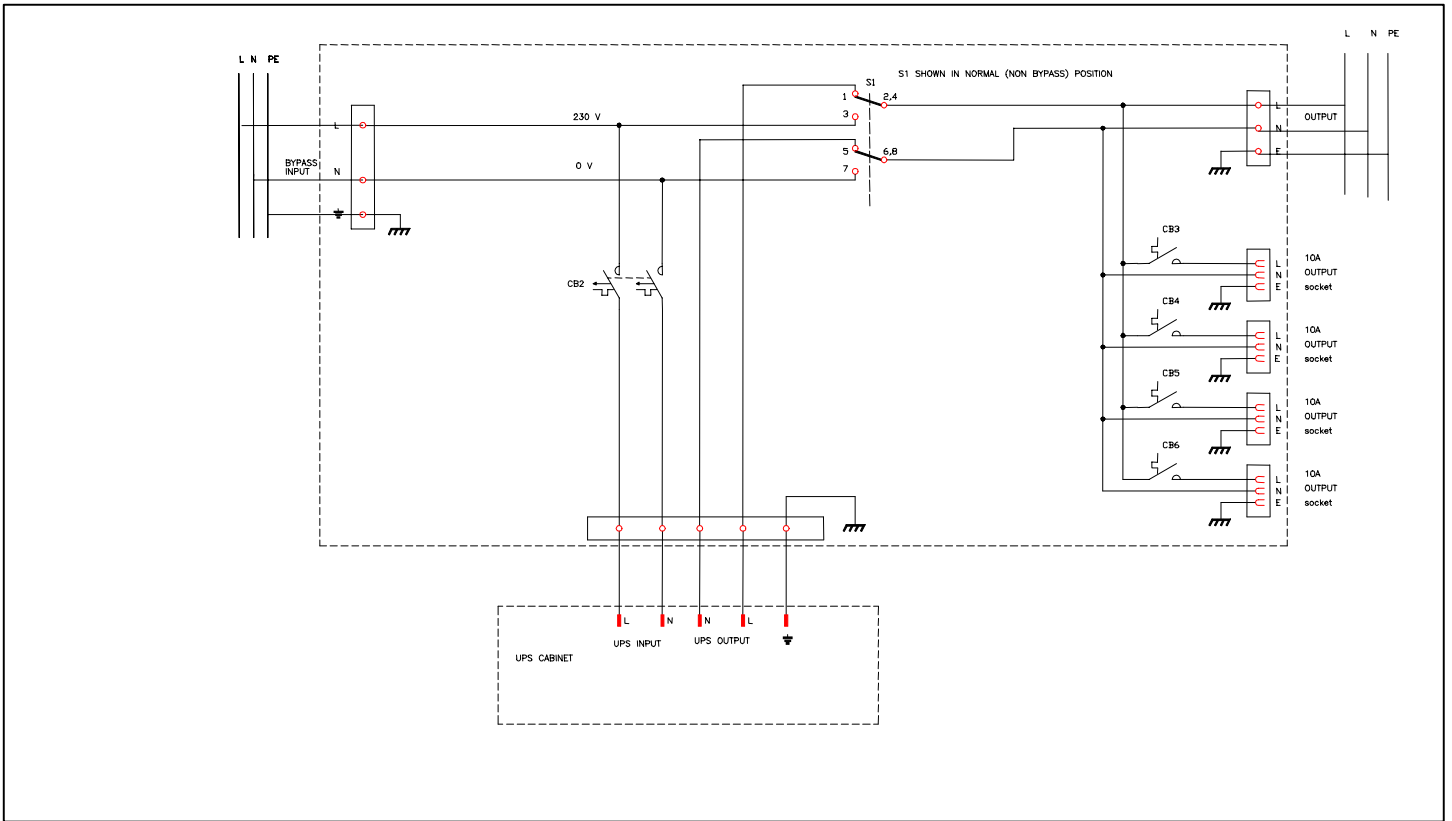

1.3 Starting UPS

Switch the Mechanical Bypass to position UPS. Follow the instructions given in User manual "Users guide to operations"

1.4 Using the Mechanical Bypass

Before switching the Mechanical bypass to bypass position you have to force the UPS to Bypass. This can be selected from UPS setting in the LCD menu (see UPS manual). After this you may switch the Mechanical Bypass to bypass position.

2. TECHNICAL SPECIFICATIONS WITH MECHANICAL BYPASS

2.1 POWER RANGE 700-3000 VA

GENERAL

Rated power	700VA, 1000 VA, 1500 VA, 2000 VA, 3000 VA at p.f 0,7
Technology	On-line, double conversion topology with automatic bypass

INPUT

Phase :	Single phase with ground
Nominal Input Voltage:	208/220/230/240/ VAC
Bypass Voltage:	184-265 VAC, Selectable
Nominal Voltage range:	120/140/160 ¹ VAC-276 VAC
Frequency:	50/60 Hz. Auto selection
Frequency window from mains	45-65 Hz
Synchronization window	+/- 3Hz.
Input Power factor:	0,97

OUTPUT

Output Voltage :	208/220/230/240 VAC, selectable
Voltage regulation:	+/- 2%
Voltage distortion:	< 8% THD at full non-linear load, < 4% THD at full linear load
Frequency regulation	+/- 0,5 % (battery mode or free running)
Transient response:	+/-6 % max from 100% to 20 % or from 20% to 100 % linear load
Overload capacity:	100-125% for 60 seconds 125-150% for 10 seconds
Efficiency:	>86%

ENVIRONMENTAL

Ambient temperature:	+0 °C.....+40 °C
Recommended temperature:	+15 °C+25 °C

¹ Values given for 33%/66%/100% loads

Storage temperature:	- 15 °C+40 °C
Cooling:	Forced air cooling
Humidity:	20%-90%, non-condensing
Audible noise:	< 45 db normal & battery mode (700-1500 VA) < 50 db normal and battery mode (2000-3000 VA)

STANDARDS

Safety:	EN50091-1
Emissions:	EN50091-2 class B
Immunity:	EN50091-2

2.2 POWER RANGE 5000-6000 VA

GENERAL

Rated power	5000 VA 6000 VA at p.f 0,7
Technology	On-line, double conversion topology with automatic bypass

INPUT

Phase :	Single phase with ground
Bypass Voltage:	184-265 VAC
Nominal Voltage range:	120/140/184 ¹ VAC-276 VAC
Frequency:	50/60 Hz. Auto selection
Frequency window from mains	45-65 Hz
Input current	30 A (6 kVA), 25 A (5 kVA) at nominal voltage
Input Power factor:	0,97

OUTPUT

Output Voltage :	208/220/230/240 VAC
Voltage regulation:	+/- 2%
Voltage distortion:	< 5% THD at full non-linear load, < 3% THD at full linear load
Frequency regulation	+/- 0,25 % (battery mode or free running)
Transient response:	+/- 9% max from 100% to 20 % or from 20% to 100 % linear load

¹ Values given for 33%/66%/100% loads

Overload capacity:	100-125% for 1 min 125-150 % for 10 seconds
Efficiency:	0,9

ENVIRONMENTAL

Ambient temperature:	+0 °C.....+40 °C
Recommended temperature:	+15 °C+25 °C
Storage temperature:	0 °C+40 °C
Cooling:	Forced air cooling
Humidity:	0-95%, non-condensing
Audible noise:	< 50 db normal mode battery mode

STANDARDS

Safety:	EN50091-1
Emissions:	EN50091-2 class A
Immunity:	EN50091-2